

Product Specification

DC-DC Converter

Key Product Features

- Size: 58.9mm x 22.8mm x 9.5mm
- Constant Frequency
- High Efficiency: 92% (typical-12Vout)
- Low Output Noise
- Input Voltage Range: 18 to 36Vdc
- Output Over Voltage Protection
- Current Limit/Short Circuit Protection
- 80% to 110% Output Trim
- No sink current from output during shutdown
- Logic ON/OFF
- MTBF = 1.3Mhrs
- RoHS Compliant
- CSA Certified to IEC 60950-1 for Basic Insulation

DPEV24-5.0-75

75 Watt



Description

The Open Frame EV Series modules are high density DC-DC converters designed for use in distributed power architectures, workstations, EDP equipment, and telecommunications. The EV Series modules may be used as fit and function replacements for industry standard Quarter Brick with 34% space savings. Using Planar Magnetics and Synchronous Rectification produce up to 75W in a 1/8th Brick Package.

Options

- Choice of Logic ON/OFF Configuration

Absolute Maximum Ratings

Parameter	MIN	MAX	UNITS	CONDITIONS
Input Voltage	18	36	Vdc	Continuous
Transient Input voltage		50	Vdc	100 msec max.
Operating Temperature	-40	85	°C	Subject to power de-rating
Storage Temperature		125	°C	
Wave Soldering Temperature, for 10 secs		260	°C	

Exceeding absolute maximum ratings may cause permanent damage and may reduce reliability

Ta=25°C, airflow rate=400LFM, Vin=Vin,nom unless noted otherwise; Full ambient operating temperature range is -40°C to 85°C with power derating

Product Specification					
Input					
Parameter	MIN	TYP	MAX	UNITS	CONDITIONS
Operation Input Voltage (Vi)	Vin,min 18	Vin,nom 24	Vin,max 36	Vdc	After start up condition
Maximum Input Current (Ii,max)			5.5	A	Vin=0 to Vin,max
Input Reflected Ripple Current Peak to Peak		20		mAp-p	Measured before input filter, 12uH inductor
Input Transient			1	A ² t	
Startup Input Voltage	17		19	V	
Shutoff Input Voltage	16		18	V	
Hysteresis	1			V	
Output					
Parameter	MIN	TYP	MAX	UNITS	CONDITIONS
Output Voltage Set Point	4.92	5.0	5.08	V	Vin=Vin,nom Io=Io, max
Line Regulation			1	% Vnom	Vin=Vin,min to Vin,max; Io=Io,max
Load Regulation			1	% Vnom	Vin=Vin,nom; Io=0A to Io,max
Temperature Regulation			1	% Vnom	Vin=Vin,nom; Io=Io,max; Ta=-40°C to 70°C
Total Output Voltage Range	Vnom-3%		Vnom+3%	V	Over sample load, line and temperature
Output Ripple and Noise See Notes		100	150	mVp-p	Peak to Peak
		30		mVrms	RMS
Output Current (Io)	0 (Iomin)		15 (Iomax)	A	
Output Current Limit (rms.)	105		140	% Iomax	Hiccup Mode
Output Short Current (rms.)			15	Arms	Hiccup Mode Rout≤10mΩ
Over Voltage Protection	110		140	% Vnom	Hiccup Mode
Efficiency (Io)	88	90.5		%	Io=Iomax
External Load Capacitance	10		5000	uF	Electrolytic Capacitor
Dynamic Response: Peak Deviation Settling Time			4 200	%Vnom μs	25% to 50% and 50% to 75% load, 0.1A/μs; Vout within 1%Vnom

- Notes:
- 1: Scope measurement should be made using a BNC connector with 1uF ceramic and 10uF aluminum electrolytic capacitor across output. Scope is set to read at 20MHz bandwidth.
 - 2: The Cold Start condition for start up is a uniform converter temperature of -40°C after thermal stabilization. An additional 2x 220uF is needed for 12V models cold startup conditions. Please contact for more information.
 - 3: The Hot Start condition for start up is a uniform converter temperature of 65°C after thermal stabilization.

Control Specifications

Parameter	MIN	TYP	MAX	UNITS	CONDITIONS
Input Logic Low: Voltage at 1mA current relative to -Vin Current at 0 volts			1 1	V mA	
Input Logic High: Enable pin voltage relative to -Vin Leakage Current			5.5 100	V uA	
Turn-On Time			100	ms	$I_o=I_{o,max}$ $V_o=90\% V_{o,set}$
Output Voltage Adjustment Setpoint	80		110	% $V_{o,set}$	
Thermal Shutdown Range (Converter hotspot temperature)	105	115	125	°C	Auto Recover

Isolation Specifications

Parameter	MIN	TYP	MAX	UNITS	CONDITIONS
Input to Output			1500	Vdc	
Isolation Resistance	10			MΩ	
Isolation Capacitance		1500		pF	

Reliability

Parameter	MIN	TYP	MAX	UNITS	CONDITIONS
MTBF		1.3		MHrs	$V_{in}=48V$, $I_{out}=80\%$, $T_{amb}=25^{\circ}C$, 400LFM

Mechanical Parameters

Parameter	MIN	TYP	MAX	UNITS	CONDITIONS
Weight		100		g	
Size	58.4mm x 36.8mm x 12mm			mm ³	

Pin Outs

Pin	Function	Pin	Function
1	+Vin	4	-Vout
		5	-Sense
2	Enable (ON/OFF)	6	Trim
		7	+Sense
3	-Vin	8	+Vout

Outline Drawing

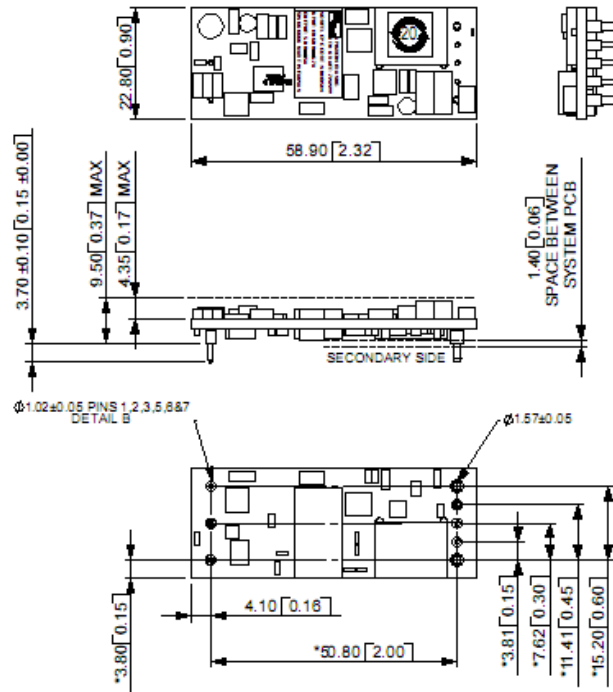

Operating Information

Enable Pin

The Enable Pin (pin 2) enables the user to control when the converter will turn on or off. This pin is referenced to $-V_{in}$ (pin 3). There are two versions available for each converter, positive logic and negative logic. For positive logic, leaving the Enable pin open or applying TTL/CMOS high voltage level turns the converter on, while pulling this pin to $-V_{in}$ or drawing more than 1mA turns it off. The negative logic is just the inverse. An external semiconductor switch or mechanical switch can be used to implement this function.

Remote Sense

The remote sense pins +Sense (pin 7) and -Sense (pin 5) allows the converter to correct for voltage drops across the connections from the converter output pins +/-Vout (pins 8 and 4 respectively) to the intended load. The +/- Sense pins should be connected at the point in the board where regulation is needed. Figure 3 shows the recommended connection.

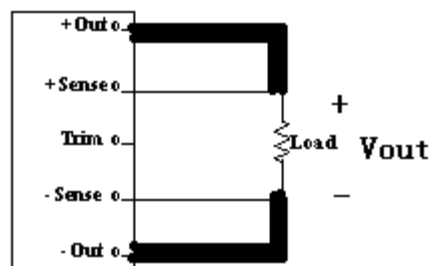
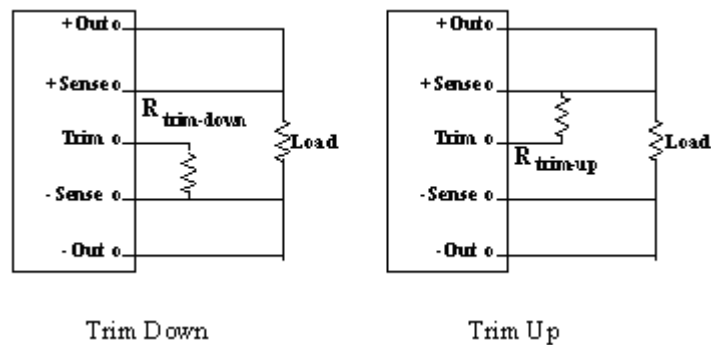

Figure 3: Remote Sense connection

The resistive drop across the connections should be small enough since Over Voltage Protection might be triggered during high load applications. The OVP circuit senses the +/-Vout pins.

Trim

The Trim pin (pin 6) allows the user to adjust the output voltage across the sense pins from the initial value. Trimming the output voltage requires the user to connect a resistor between Trim and +Vout for output voltage trim up, or connect a resistor between Trim and -Vout for output voltage trim down. The functions for trim up, trim down, and the circuit implementation is shown in the figure 4.



$$R_{trim-down} = \frac{511}{\Delta\%} - 10.22 \text{ kOhms}$$

$$R_{trim-up} = \frac{5.11 \times V_{nominal} \times (100 + \Delta\%)}{1.225 \Delta\%} - \frac{511}{\Delta\%} - 10.22 \text{ kOhms}$$

$$\Delta\% = \left| \frac{V_{nominal} - V_{desired}}{V_{nominal}} \right| \times 100\%$$

Figure 4: TRIM Function

Example: 5Vout part

Trim Up to 5.5V

$\Delta\% = 10\%$

$$R_{trim-up} = (5.11 * 5 * (100 + 10) / 1.225 * 10) - (511 / 10) - 10.22 = 168.11 \text{ kohms}$$

Trim Down to 4.5V

$\Delta\% = 10\%$

$$R_{trim-down} = (511 / 10) - 10.22 = 40.88 \text{ kohms}$$

There is an upper limit to the trim up since the OVP level is fixed. Trimming the output voltage too high may trigger the OVP circuit during higher load applications or during transients.

Current Limit Protection

The EV series modules include over current protection that allows them to withstand prolonged overloads or short circuit conditions on the output without over heating. The EV series employs hiccup mode protection such that the output shuts down during these conditions, waits for a predetermined time (~500mS), and tries to restart. If the overload condition is still present, the converter will stop trying to increase the output voltage and repeat the cycle.

Over Voltage Protection

The EV series modules have output over voltage protection. In the event of an over voltage condition in the output pins, the converter will shut down immediately. Similar to hiccup mode, it will make continuous attempts to start up until the over voltage is gone and resume normal operation automatically.

Input Under-Voltage Lockout

The EV series is designed to turn off when the input voltage is too low. This is done to avoid stressing the input side circuitry of the primary circuit. The lockout circuit is a comparator with hysteresis, thus avoiding the converter jumping from on-off condition when crossing the UVLO threshold.

Over Temperature Protection

The EV series modules are protected from thermal overload by an internal over temperature protection IC. When the PCB temperature sense point reaches 125°C, the converter will shut down immediately. The converter will attempt to restart when the temperature has dropped at least 10°C below the Over Temperature threshold.

Thermal Considerations

The EV series are designed to operate in a wide range of thermal environments. However, enough cooling should be provided to ensure reliable performance. Heat is removed from the converter in three ways: conduction, convection, and radiation.

Improved cooling by convection can be done by increasing the airflow through the module. The available load current for a given ambient air temperature is in the de-rating curves section. The test is done using the test fixture shown in figure 5.

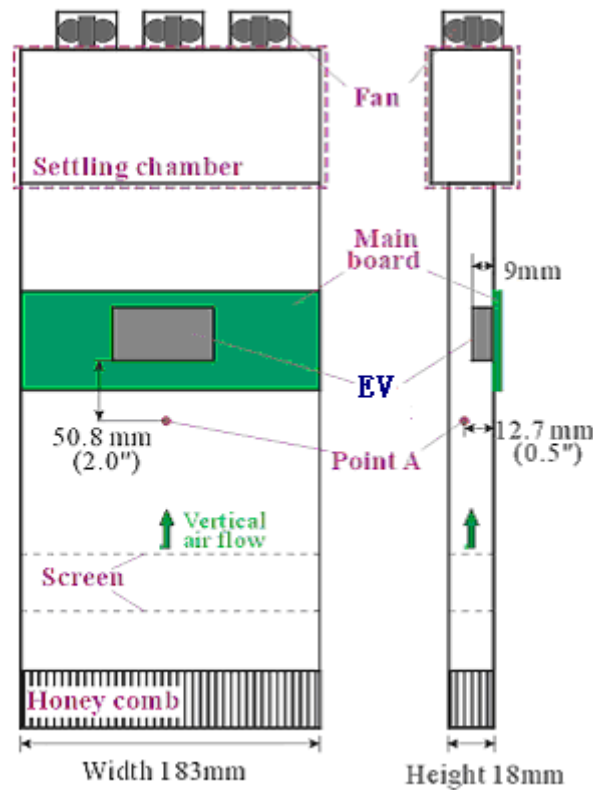
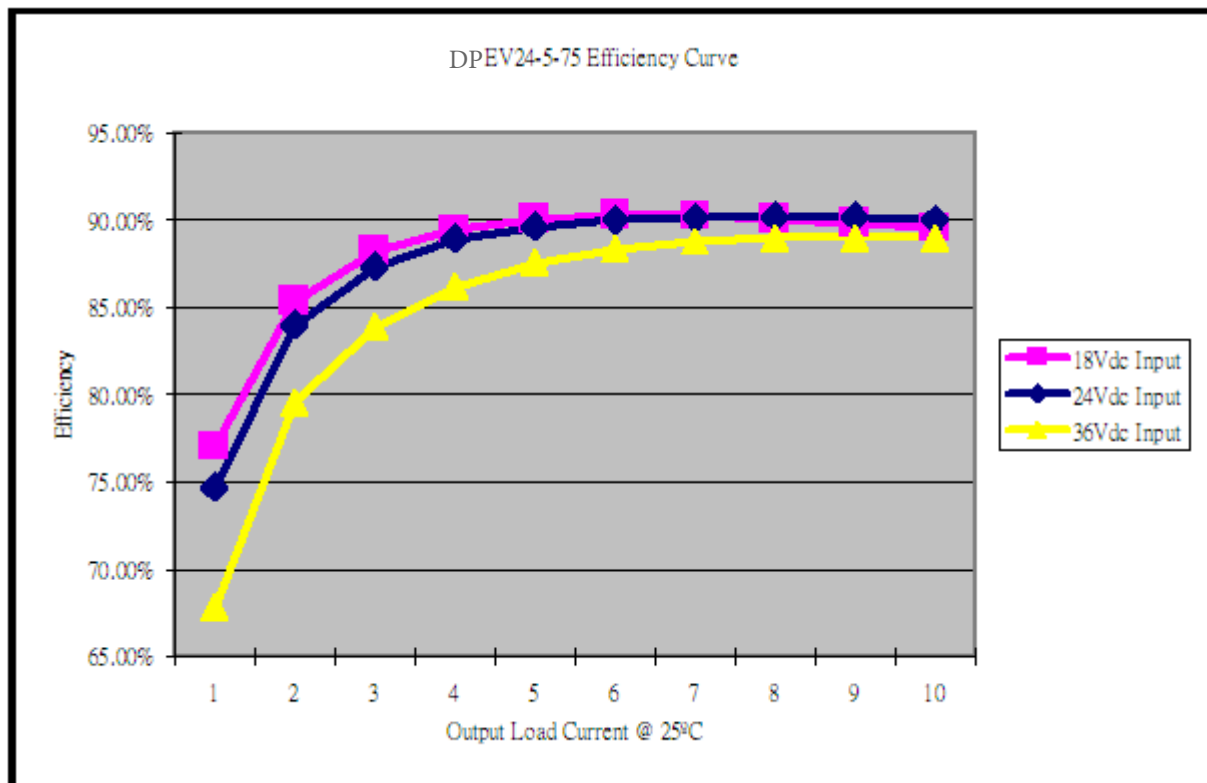

Figure 5: Thermal Test Fixture

Proper cooling can be verified by monitoring the temperature of the critical components of the power stage. Each of the selected critical components was monitored by using thermocouple. The generation of the thermal de-rating curves involves extensive thermal testing at different combinations of input voltage, ambient air temperature, load current, and airflow with the given test fixture.

However, the final temperature of the module in the final system will depend again on several factors, including host PCB size, number of layers, and copper weight, airflow direction and turbulence, operating ambient temperatures, etc... It is highly recommended to verify the thermal performance of the converter when included in the end system.

Efficiency Curves



Thermal Images (Airflow: Pin 3 to Pin 1)

